

NUTR 50110 A

Dimensions

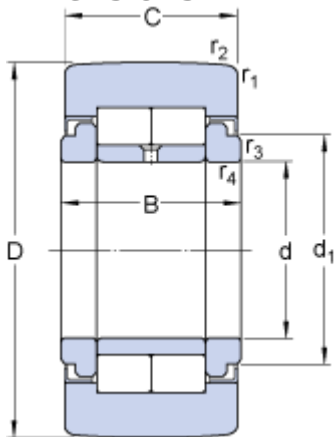

D		110	mm
d		50	mm
C		30	mm
B		32	mm
d ₁		59.8	mm
r _{1,2}	min.	1.1	mm
r, r _{3,4}	min.	0.6	mm

Calculation data

Basic dynamic load rating	C		78.1	kN
Basic static load rating	C		116	kN
Fatigue load limit	P _u		14.3	kN
Maximum dynamic radial loads	F _r	max.	98	kN
Maximum static radial loads	F _{0r}	max.	140	kN
Limiting speed			1600	r/min

Mass

Mass support roller			1.69	kg
---------------------	--	--	------	----