

NUP 217 ECP

SKF Explorer

Dimensions

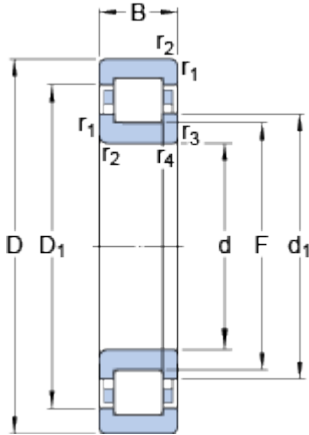

d	85	mm
D	150	mm
B	28	mm
d ₁	≈ 107	mm
D ₁	≈ 130.3	mm
F	100.5	mm
r _{1,2}	min. 2	mm
r _{3,4}	min. 2	mm

Abutment dimensions

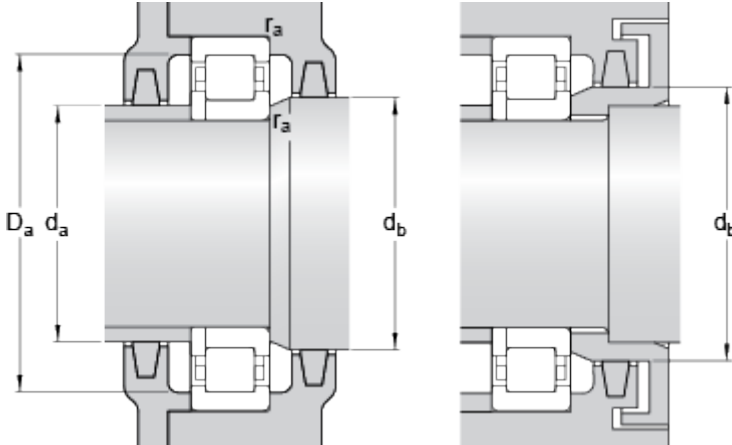

d _a	min. 96	mm
d _b	min. 110	mm
D _a	max. 138.5	mm
r _a	max. 2	mm

Calculation data

Basic dynamic load rating	C	190	kN
Basic static load rating	C	200	kN
Fatigue load limit	P _u	25	kN
Reference speed		4800	r/min
Limiting speed		5300	r/min
Calculation factor	k _r	0.15	
Limiting value	e	0.2	
Axial load factor	Y	0.6	

Mass

Mass bearing		1.9	kg
--------------	--	-----	----