

NJ 2212 ECJ

SKF Explorer

Dimensions

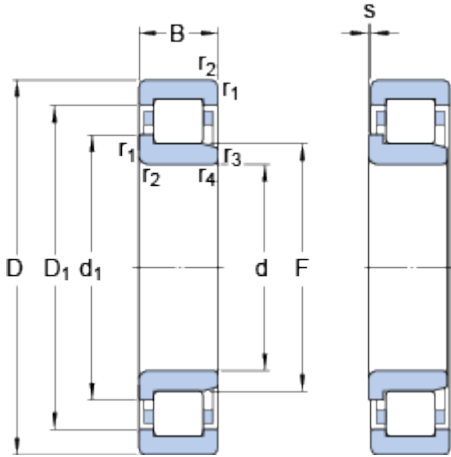

d	60	mm
D	110	mm
B	28	mm
d ₁	≈ 77.5	mm
D ₁	≈ 95	mm
F	72	mm
r _{1,2}	min. 1.5	mm
r _{3,4}	min. 1.5	mm
s	max. 1.4	mm

Abutment dimensions

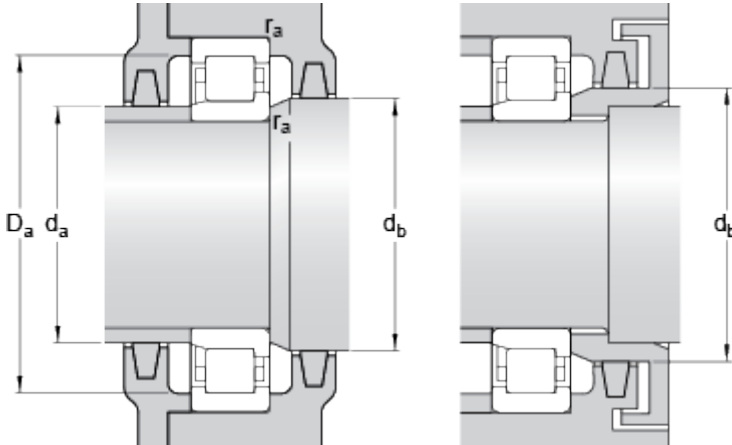

d _a	min. 68	mm
d _a	max. 70	mm
d _b	min. 80	mm
D _a	max. 101	mm
r _a	max. 1.5	mm

Calculation data

Basic dynamic load rating	C	146	kN
Basic static load rating	C	153	kN
Fatigue load limit	P _u	20	kN
Reference speed		6700	r/min
Limiting speed		7500	r/min
Calculation factor	k _r	0.2	
Limiting value	e	0.3	
Axial load factor	Y	0.4	

Mass

Mass bearing	1.1	kg
--------------	-----	----

Associated products

Angle ring	HJ 212 EC
------------	-----------

