

# NJ 219 ECP

SKF Explorer

## Dimensions

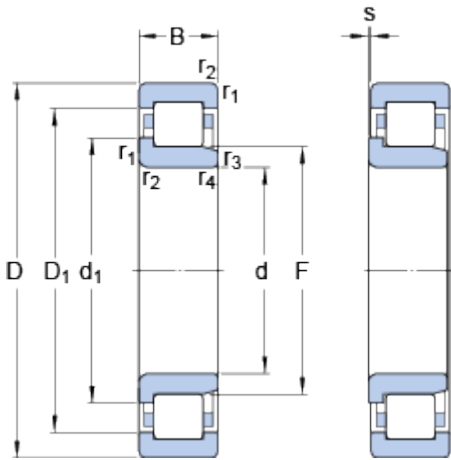

d	95	mm
D	170	mm
B	32	mm
d <sub>1</sub>	≈ 120	mm
D <sub>1</sub>	≈ 147.4	mm
F	112.5	mm
r <sub>1,2</sub>	min. 2.1	mm
r <sub>3,4</sub>	min. 2.1	mm
s	max. 1.7	mm

## Abutment dimensions

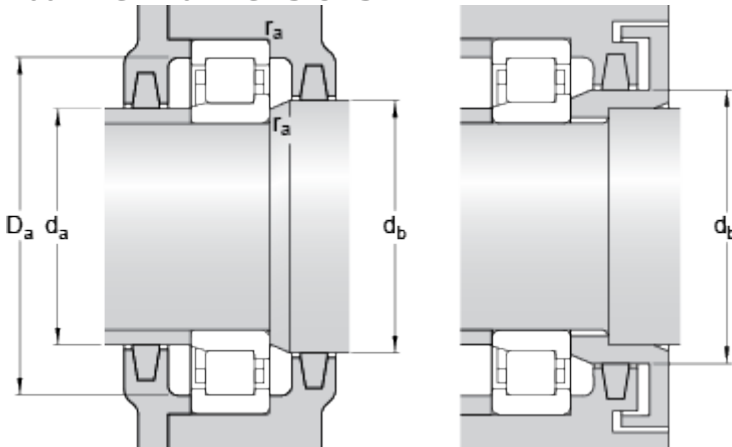

d <sub>a</sub>	min. 107	mm
d <sub>a</sub>	max. 110	mm
d <sub>b</sub>	min. 123	mm
D <sub>a</sub>	max. 157.8	mm
r <sub>a</sub>	max. 2	mm

## Calculation data

Basic dynamic load rating	C	255	kN
Basic static load rating	C	265	kN
Fatigue load limit	P <sub>u</sub>	32.5	kN
Reference speed		4300	r/min
Limiting speed		4800	r/min
Calculation factor	k <sub>r</sub>	0.15	
Limiting value	e	0.2	
Axial load factor	Y	0.6	

## Mass

Mass bearing	2.92	kg
--------------	------	----

## Associated products

Angle ring	HJ 219 EC
------------	-----------

