

NJ 218 ECP

SKF Explorer

Dimensions

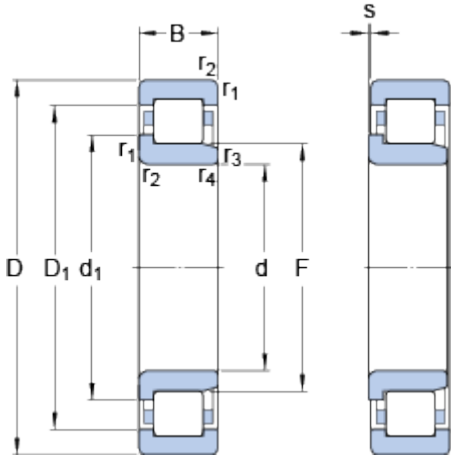

d	90	mm
D	160	mm
B	30	mm
d ₁	≈ 114	mm
D ₁	≈ 138.45	mm
F	107	mm
r _{1,2}	min. 2	mm
r _{3,4}	min. 2	mm
s	max. 1.8	mm

Abutment dimensions

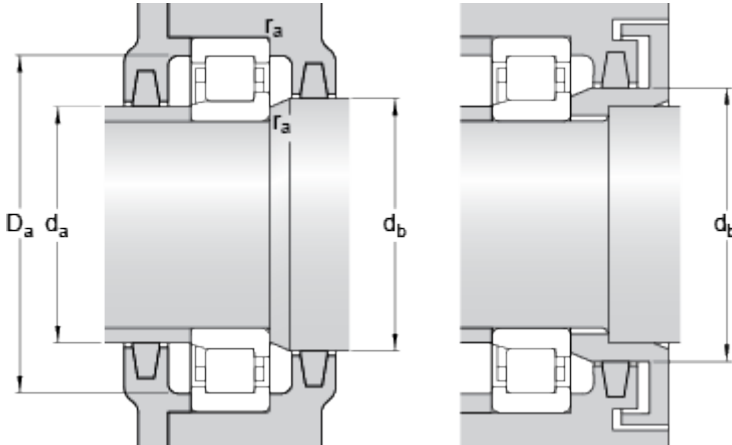

d _a	min. 101	mm
d _a	max. 104	mm
d _b	min. 117	mm
D _a	max. 149	mm
r _a	max. 2	mm

Calculation data

Basic dynamic load rating	C	208	kN
Basic static load rating	C	220	kN
Fatigue load limit	P _u	27	kN
Reference speed		4500	r/min
Limiting speed		5000	r/min
Calculation factor	k _r	0.15	
Limiting value	e	0.2	
Axial load factor	Y	0.6	

Mass

Mass bearing	2.32	kg
--------------	------	----

Associated products

Angle ring	HJ 218 EC
------------	-----------

