

# NJ 211 ECJ

SKF Explorer

## Dimensions

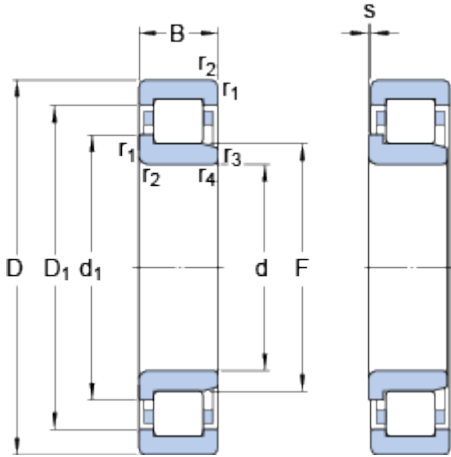

d	55	mm
D	100	mm
B	21	mm
d <sub>1</sub>	≈ 70.8	mm
D <sub>1</sub>	≈ 85.6	mm
F	66	mm
r <sub>1,2</sub>	min. 1.5	mm
r <sub>3,4</sub>	min. 1.1	mm
s	max. 1	mm

## Abutment dimensions

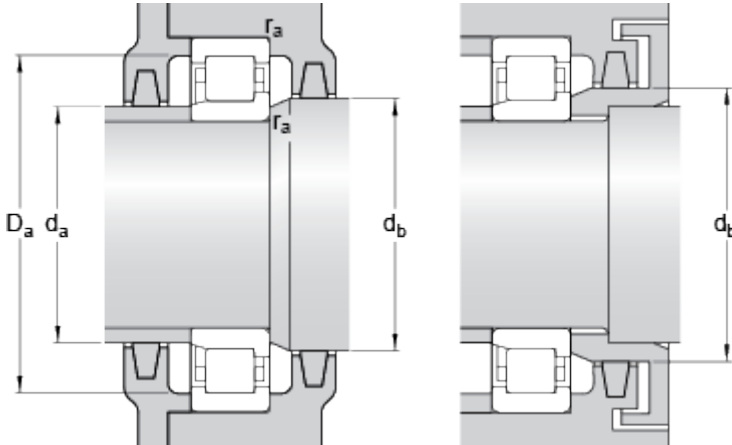

d <sub>a</sub>	min. 63	mm
d <sub>a</sub>	max. 64	mm
d <sub>b</sub>	min. 73	mm
D <sub>a</sub>	max. 91.4	mm
r <sub>a</sub>	max. 1.5	mm

## Calculation data

Basic dynamic load rating	C	96.5	kN
Basic static load rating	C	95	kN
Fatigue load limit	P <sub>u</sub>	12.2	kN
Reference speed		7500	r/min
Limiting speed		8000	r/min
Calculation factor	k <sub>r</sub>	0.15	
Limiting value	e	0.2	
Axial load factor	Y	0.6	

## Mass

Mass bearing	0.7	kg
--------------	-----	----

## Associated products

Angle ring	HJ 211 EC
------------	-----------

