

NATR 8 PPA

Dimensions

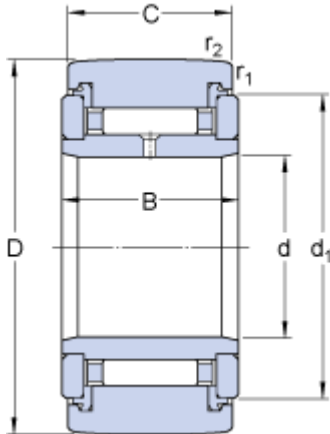

D	24	mm
d	8	mm
C	14	mm
B	15	mm
d ₁	19	mm
r _{1,2}	min. 0.3	mm

Calculation data

Basic dynamic load rating	C	5.28	kN
Basic static load rating	C	6.1	kN
Fatigue load limit	P _u	0.695	kN
Maximum dynamic radial loads	F _r	max. 5.2	kN
Maximum static radial loads	F _{0r}	max. 7.35	kN
Limiting speed		5000	r/min

Mass

Mass support roller		0.038	kg
---------------------	--	-------	----