

NATR 5 PPA

Dimensions

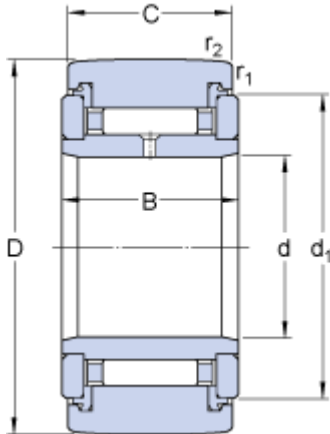

D	16	mm
d	5	mm
C	11	mm
B	12	mm
d ₁	12.5	mm
r _{1,2}	min. 0.15	mm

Calculation data

Basic dynamic load rating	C	3.14	kN
Basic static load rating	C	3.2	kN
Fatigue load limit	P _u	0.345	kN
Maximum dynamic radial loads	F _r	max. 2.9	kN
Maximum static radial loads	F _{0r}	max. 4.15	kN
Limiting speed		6000	r/min

Mass

Mass support roller		0.014	kg
---------------------	--	-------	----