

NATR 40 PPA

Dimensions

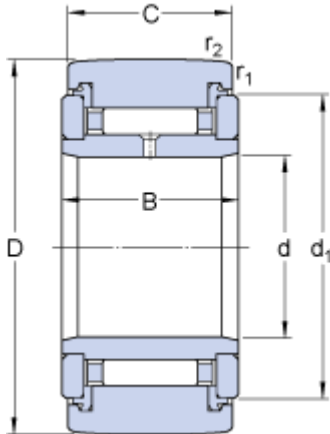

D	80	mm
d	40	mm
C	30	mm
B	32	mm
d ₁	66	mm
r _{1,2}	min. 1.1	mm

Calculation data

Basic dynamic load rating	C	31.9	kN
Basic static load rating	C	57	kN
Fatigue load limit	P _u	7.1	kN
Maximum dynamic radial loads	F _r	max. 41.5	kN
Maximum static radial loads	F _{0r}	max. 58.5	kN
Limiting speed		1500	r/min

Mass

Mass support roller		0.8	kg
---------------------	--	-----	----