

KR 72 PPA

Dimensions

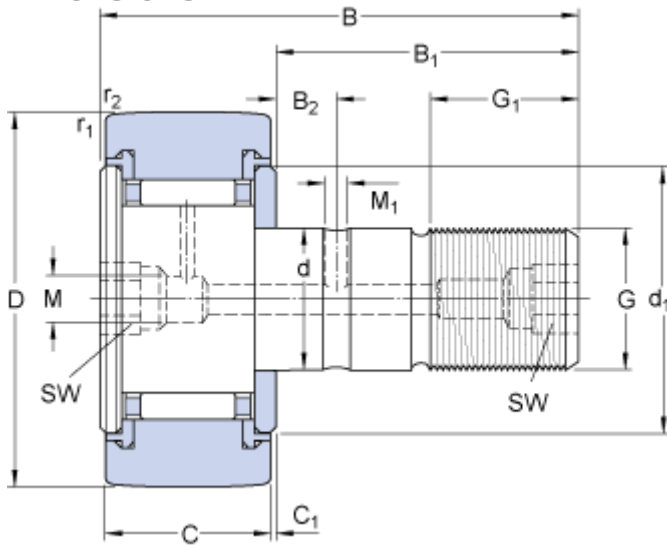

D	72	mm
d	24	mm
B	80	mm
C	29	mm
B ₁	49.5	mm
B ₂	11	mm
C ₁	0.8	mm
d ₁	44	mm
G	M 24x1.5	
G ₁	25	mm
M	8	mm
M ₁	4	mm
SW	14	mm
r _{1,2}	min. 1.1	mm

Calculation data

Basic dynamic load rating	C	26	kN
Basic static load rating	C	48	kN
Fatigue load limit	P _u	6	kN
Maximum dynamic radial loads	F _r	max. 100	kN
Maximum static radial loads	F _{0r}	max. 143	kN
Limiting speed		2400	r/min

Mass

Mass cam follower	1.01	kg
-------------------	------	----

Mounting information

Recommended tightening torque	220	N·m
-------------------------------	-----	-----

Included products

Grease fitting	NIP A3x9.5
Hexagonal nut	M 24x1.5

Associated products

Lubrication adapter	AP 14
---------------------	-------

