

KR 26 PPA

Dimensions

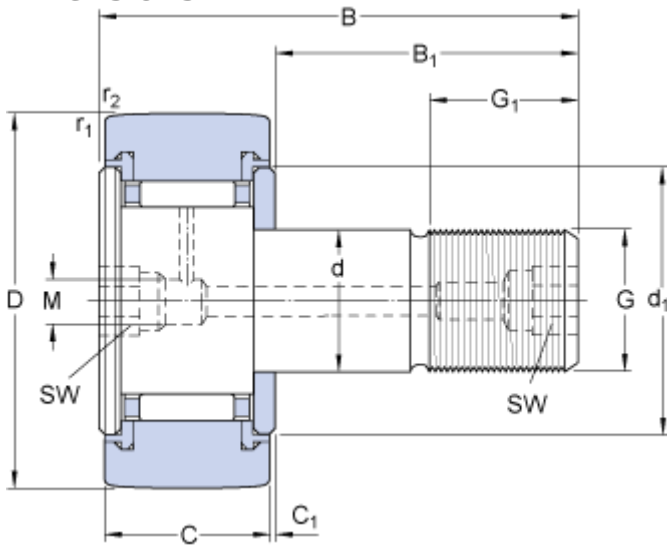

D	26	mm
d	10	mm
B	36	mm
C	12	mm
B ₁	23	mm
C ₁	0.6	mm
d ₁	17.5	mm
G	M 10x1	
G ₁	12	mm
M	4	mm
SW	5	mm
r _{1,2}	min. 0.3	mm

Calculation data

Basic dynamic load rating	C	4.84	kN
Basic static load rating	C	6	kN
Fatigue load limit	P _u	0.655	kN
Maximum dynamic radial loads	F _r	max. 9.3	kN
Maximum static radial loads	F _{0r}	max. 13.2	kN
Limiting speed		5300	r/min

Mass

Mass cam follower	0.057	kg
-------------------	-------	----

Mounting information

Recommended tightening torque	15	N·m
-------------------------------	----	-----

Included products

Grease fitting	NIP A1x4.5
Hexagonal nut	M 10x1