

KRV 80 PPA

Dimensions

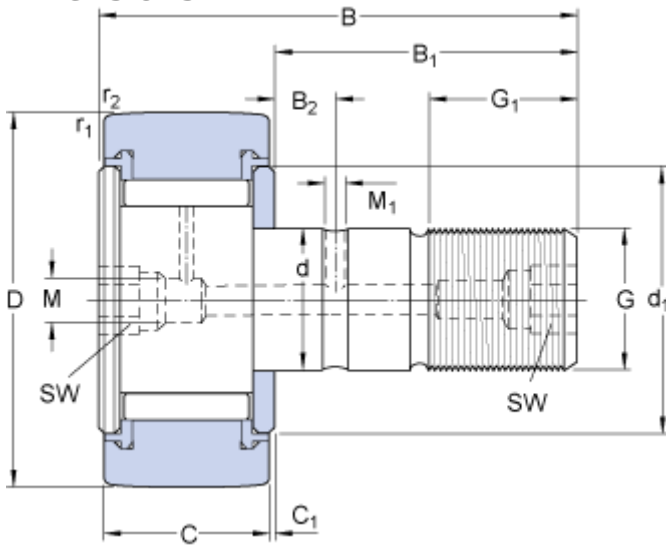

D	80	mm
d	30	mm
B	100	mm
C	35	mm
B ₁	63	mm
B ₂	15	mm
C ₁	1	mm
d ₁	53	mm
G	M 30x1.5	
G ₁	32	mm
M	8	mm
M ₁	4	mm
SW	14	mm
r _{1,2}	min. 1.1	mm

Calculation data

Basic dynamic load rating	C	45.7	kN
Basic static load rating	C	114	kN
Fatigue load limit	P _u	14	kN
Maximum dynamic radial loads	F _r	max. 122	kN
Maximum static radial loads	F _{or}	max. 176	kN
Limiting speed		1400	r/min

Mass

Mass cam follower	1.64	kg
-------------------	------	----

Mounting information

Recommended tightening torque	450	N·m
-------------------------------	-----	-----

Included products

Grease fitting	NIP A3x9.5
Hexagonal nut	M 30x1.5

Associated products

Lubrication adapter	AP 14
---------------------	-------

