

# KRV 32 PPXA

## Dimensions

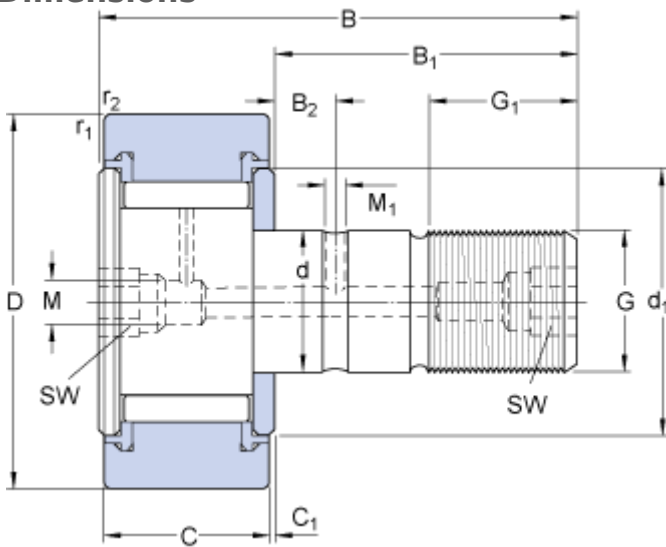

D	32	mm
d	12	mm
B	40	mm
C	14	mm
B <sub>1</sub>	25	mm
B <sub>2</sub>	6	mm
C <sub>1</sub>	0.6	mm
d <sub>1</sub>	23	mm
G	M 12x1.5	
G <sub>1</sub>	13	mm
M	4	mm
M <sub>1</sub>	3	mm
SW	6	mm
r <sub>1,2</sub>	min. 0.6	mm

## Calculation data

Basic dynamic load rating	C	9.35	kN
Basic static load rating	C	15.3	kN
Fatigue load limit	P <sub>u</sub>	1.76	kN
Maximum dynamic radial loads	F <sub>r</sub>	max. 14.3	kN
Maximum static radial loads	F <sub>0r</sub>	max. 20.4	kN
Limiting speed		3200	r/min

## Mass

Mass cam follower	0.1	kg
-------------------	-----	----

## Mounting information

Recommended tightening torque	22	N·m
-------------------------------	----	-----

## Included products

Grease fitting	NIP A1x4.5
Hexagonal nut	M 12x1.5