

KM 16

Dimensions

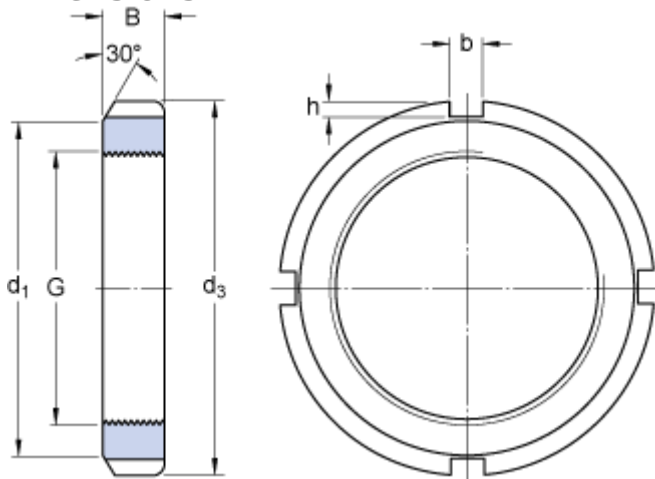

G	M 80x2	
d_3	105	mm
B	15	mm
d_1	95	mm
b	8	mm
h	3.5	mm

Calculation data

Axial static load carrying capacity 173 kN

Mass

Mass lock nut 0.36 kg

Mounting information

Associated spanner HN 16

Associated products

Lock washer / Locking clip [MB 16](#)