

KM 10

Dimensions

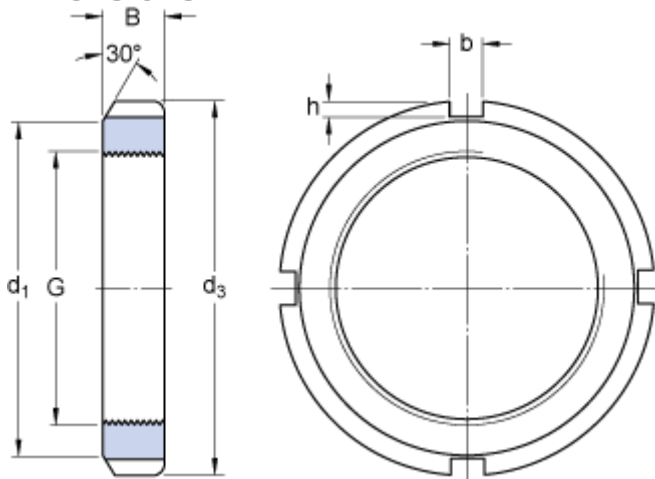

G	M 50x1.5	
d_3	70	mm
B	11	mm
d_1	61	mm
b	6	mm
h	2.5	mm

Calculation data

Axial static load carrying capacity 91.5 kN

Mass

Mass lock nut 0.14 kg

Mounting information

Associated spanner HN 10-11

Associated products

Lock washer / Locking clip [MB 10](#)