

H 322

Dimensions

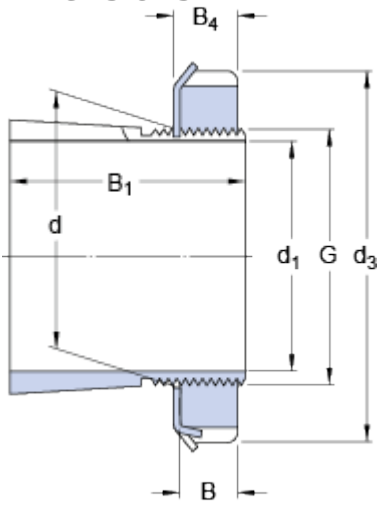

| | | |
|-------|---------|----|
| d_1 | 100 | mm |
| d | 110 | mm |
| d_3 | 145 | mm |
| B_1 | 77 | mm |
| B | 19 | mm |
| B_4 | 21 | mm |
| G | M 110x2 | |

Mass

Mass adapter sleeve assembly

2.26

kg

Included products

Lock nut

[KM 22](#)

Locking device

[MB 22](#)

Associated products

Hydraulic nut

[HMV 22 E](#)