

H 319

Dimensions

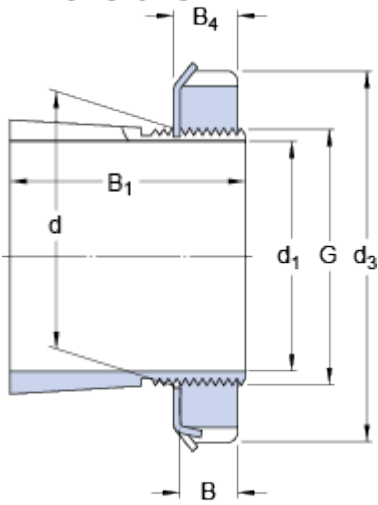

d_1	85	mm
d	95	mm
d_3	125	mm
B_1	68	mm
B	17	mm
B_4	19	mm
G	M 95x2	

Mass

Mass adapter sleeve assembly

1.59

kg

Included products

Lock nut

[KM 19](#)

Locking device

[MB 19](#)

Associated products

Hydraulic nut

[HMV 19 E](#)