

# H 315

## Dimensions

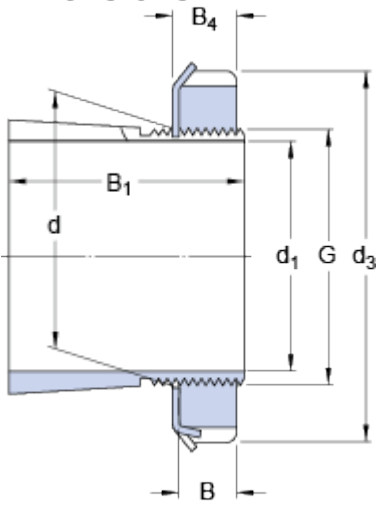

|       |        |    |
|-------|--------|----|
| $d_1$ | 65     | mm |
| $d$   | 75     | mm |
| $d_3$ | 98     | mm |
| $B_1$ | 55     | mm |
| $B$   | 13     | mm |
| $B_4$ | 14.5   | mm |
| $G$   | M 75x2 |    |

## Mass

Mass adapter sleeve assembly

0.87

kg

## Included products

Lock nut

[KM 15](#)

Locking device

[MB 15](#)

## Associated products

Hydraulic nut

[HMV 15 E](#)