

# H 3130

## Dimensions

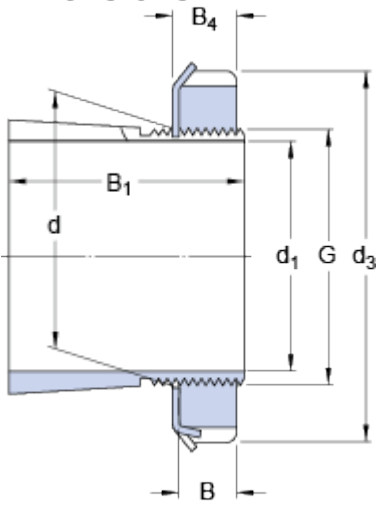

$d_1$	135	mm
$d$	150	mm
$d_3$	195	mm
$B_1$	111	mm
$B$	24	mm
$B_4$	26	mm
$G$	M 150x2	

## Mass

Mass adapter sleeve assembly

5.25

kg

## Included products

Lock nut

[KM 30](#)

Locking device

[MB 30](#)

## Associated products

Hydraulic nut

[HMV 30 E](#)