

# H 311

## Dimensions

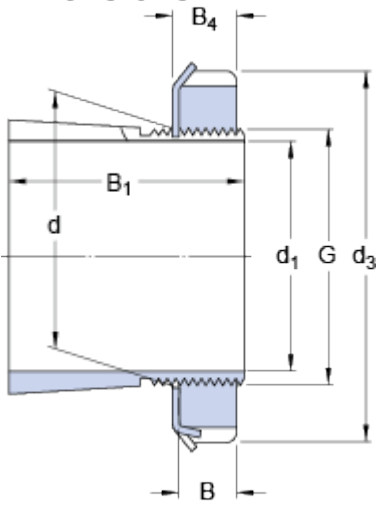

$d_1$	50	mm
$d$	55	mm
$d_3$	75	mm
$B_1$	45	mm
$B$	11	mm
$B_4$	12.5	mm
$G$	M 55x2	

## Mass

Mass adapter sleeve assembly

0.37

kg

## Included products

Lock nut

[KM 11](#)

Locking device

[MB 11](#)

## Associated products

Hydraulic nut

HMV 11 E