

H 310

Dimensions

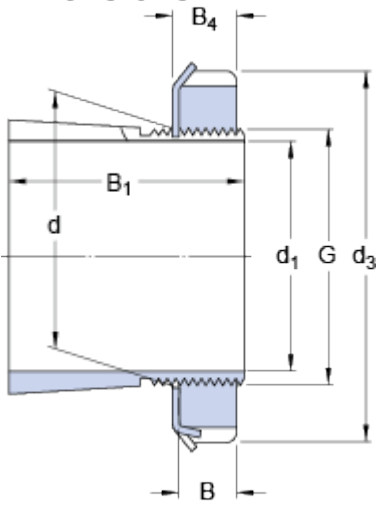

d_1	45	mm
d	50	mm
d_3	70	mm
B_1	42	mm
B	11	mm
B_4	12	mm
G	M 50x1.5	

Mass

Mass adapter sleeve assembly

0.31

kg

Included products

Lock nut

[KM 10](#)

Locking device

[MB 10](#)

Associated products

Hydraulic nut

[HMV 10 E](#)