

# H 3036

## Dimensions

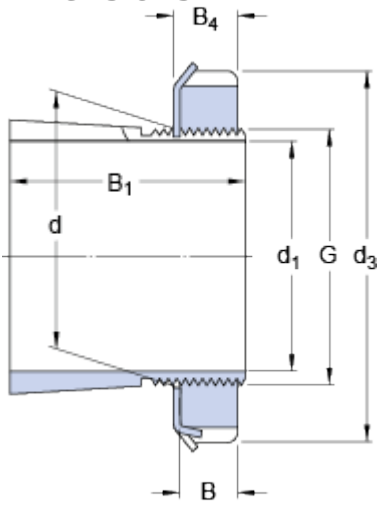

$d_1$	160	mm
$d$	180	mm
$d_3$	210	mm
$B_1$	109	mm
$B$	27	mm
$B_4$	29.5	mm
$G$	M 180x3	

## Mass

Mass adapter sleeve assembly

6.7 kg

## Included products

Lock nut

[KML 36](#)

Locking device

[MBL 36](#)

## Associated products

Hydraulic nut

[HMV 36 E](#)