

H 3028

Dimensions

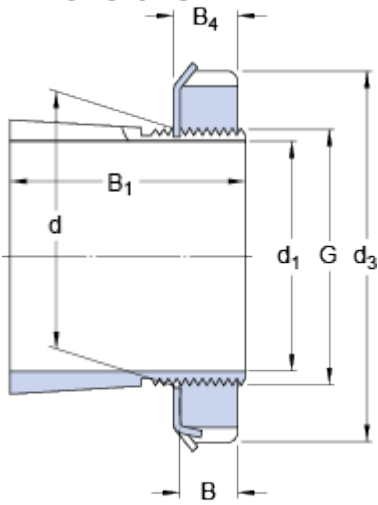

d_1	125	mm
d	140	mm
d_3	165	mm
B_1	82	mm
B	22	mm
B_4	24	mm
G	M 140x2	

Mass

Mass adapter sleeve assembly

3.05

kg

Included products

Lock nut

[KML 28](#)

Locking device

[MBL 28](#)

Associated products

Hydraulic nut

[HMV 28 E](#)