

# HK 5020

## Dimensions

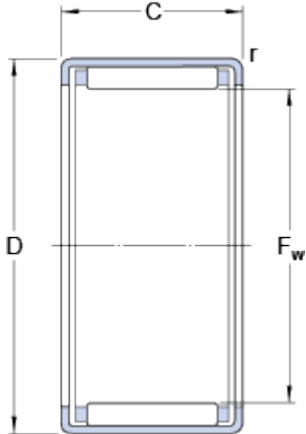

F <sub>w</sub>	50	mm
D	58	mm
C	20	mm
r	min. 0.8	mm

## Calculation data

Basic dynamic load rating	C	29.2	kN
Basic static load rating	C	63	kN
Fatigue load limit	P <sub>u</sub>	7.8	kN
Reference speed		5000	r/min
Limiting speed		5600	r/min

## Mass

Mass bearing		0.07	kg
Designation		HK 5020	

## Associated products

Inner ring LR series		LR 45x50x20.5
Radial shaft seal with a low cross-sectional height, single lip		<a href="#">G 50x58x4</a>
Radial shaft seal with a low cross-sectional height, double lip		<a href="#">SD 50x58x4</a>