

HK 4520

Dimensions

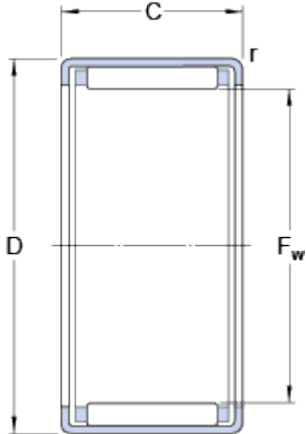

F_w	45	mm
D	52	mm
C	20	mm
r	min. 0.8	mm

Calculation data

Basic dynamic load rating	C	26	kN
Basic static load rating	C	60	kN
Fatigue load limit	P_u	7.2	kN
Reference speed		5600	r/min
Limiting speed		6300	r/min

Mass

Mass bearing		0.056	kg
Designation		HK 4520	

Associated products

Inner ring IR series		IR 40x45x20.5
Radial shaft seal with a low cross-sectional height, single lip		G 45x52x4
Radial shaft seal with a low cross-sectional height, double lip		SD 45x52x4