

HK 4516

Dimensions

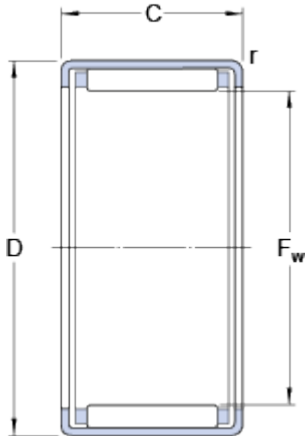

F_w	45	mm
D	52	mm
C	16	mm
r	min. 0.8	mm

Calculation data

Basic dynamic load rating	C	20.5	kN
Basic static load rating	C	43	kN
Fatigue load limit	P_u	5.1	kN
Reference speed		5600	r/min
Limiting speed		6300	r/min

Mass

Mass bearing		0.047	kg
Designation		HK 4516	

Associated products

Inner ring IR series	IR 40x45x17
Inner ring LR series	LR 40x45x16.5
Radial shaft seal with a low cross-sectional height, single lip	G 45x52x4
Radial shaft seal with a low cross-sectional height, double lip	SD 45x52x4