

# HK 2518 RS

## Dimensions

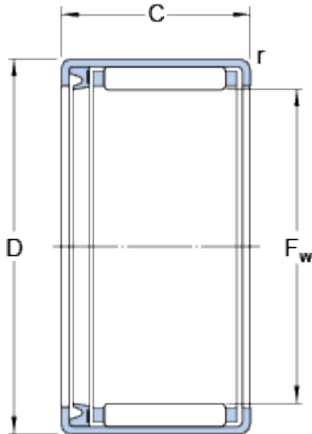

$F_w$	25	mm
D	32	mm
C	18	mm
r	min. 0.8	mm

## Calculation data

Basic dynamic load rating	C	15.1	kN
Basic static load rating	C	24	kN
Fatigue load limit	$P_u$	2.85	kN
Limiting speed		6700	r/min

## Mass

Mass bearing		0.029	kg
--------------	--	-------	----

Designation	HK 2518 RS
-------------	------------

## Associated products

Inner ring IR series	IR 20x25x20.5
Inner ring LR series	LR 20x25x20.5