

HK 1812

Dimensions

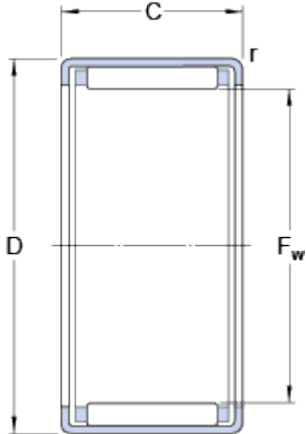

F_w	18	mm
D	24	mm
C	12	mm
r	min. 0.8	mm

Calculation data

Basic dynamic load rating	C	7.92	kN
Basic static load rating	C	11.2	kN
Fatigue load limit	P_u	1.27	kN
Reference speed		13000	r/min
Limiting speed		15000	r/min

Mass

Mass bearing		0.013	kg
Designation		HK 1812	

Associated products

Inner ring LR series	LR 15x18x12.5
Radial shaft seal with a low cross-sectional height, single lip	G 18x24x3
Radial shaft seal with a low cross-sectional height, double lip	SD 18x24x3