

HK 1012 RS

Dimensions

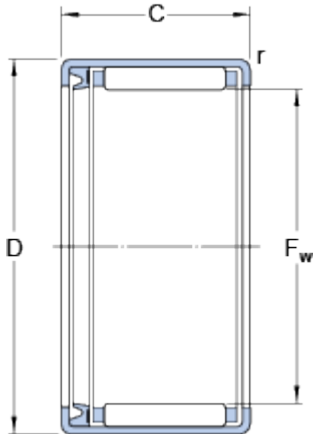

F_w	10	mm
D	14	mm
C	12	mm
r	min. 0.4	mm

Calculation data

Basic dynamic load rating	C	4.29	kN
Basic static load rating	C	5.3	kN
Fatigue load limit	P_u	0.57	kN
Limiting speed		12000	r/min

Mass

Mass bearing		0.0042	kg
Designation		HK 1012 RS	