

HK 0810 RS

Dimensions

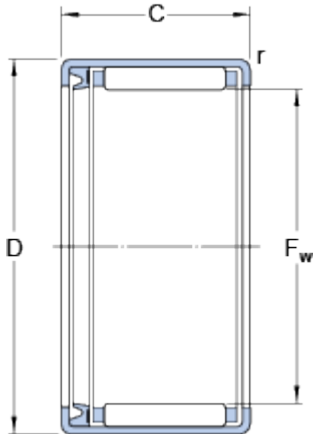

F _w	8	mm
D	12	mm
C	10	mm
r	min. 0.4	mm

Calculation data

Basic dynamic load rating	C	2.7	kN
Basic static load rating	C	2.75	kN
Fatigue load limit	P _u	0.285	kN
Limiting speed		13000	r/min

Mass

Mass bearing		0.003	kg
Designation		HK 0810 RS	