

HK 0810

Dimensions

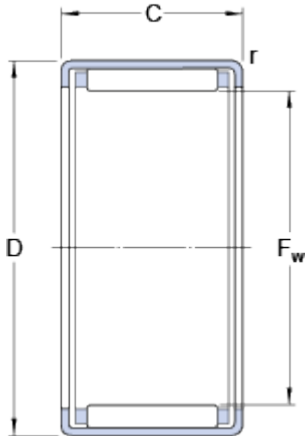

F_w	8	mm
D	12	mm
C	10	mm
r	min. 0.4	mm

Calculation data

Basic dynamic load rating	C	3.69	kN
Basic static load rating	C	4.05	kN
Fatigue load limit	P_u	0.44	kN
Reference speed		19000	r/min
Limiting speed		22000	r/min

Mass

Mass bearing		0.003	kg
Designation		HK 0810	

Associated products

Inner ring IR series		IR 5x8x12
Radial shaft seal with a low cross-sectional height, single lip		G 8x12x3