

GE 90 ES-2RS

Dimensions

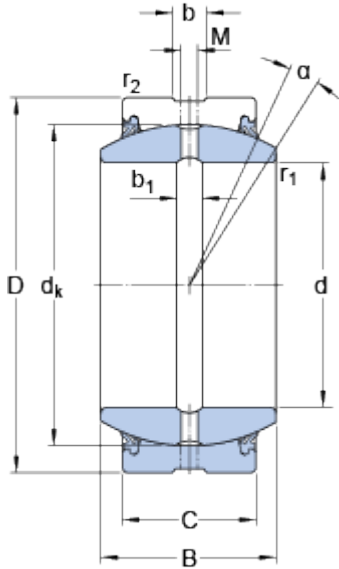

d	90	mm
D	130	mm
B	60	mm
C	50	mm
α	5	°
d_k	115	mm
b	9.5	mm
b_1	9.5	mm
M	5	mm
r_1	min. 1	mm
r_2	min. 1	mm

Abutment dimensions

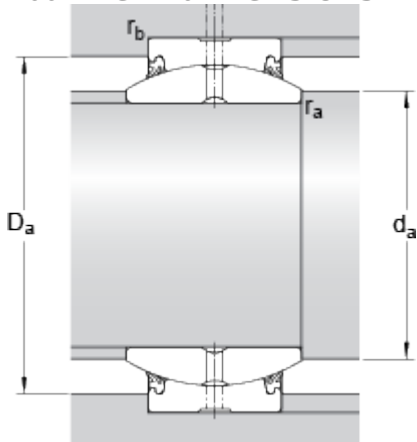

d_a	min.	97.4	mm
d_a	max.	98.1	mm
D_a	min.	112.9	mm
D_a	max.	123.5	mm
r_a	max.	1	mm
r_b	max.	1	mm

Calculation data

Basic dynamic load rating	C	490	kN
Basic static load rating	C	2450	kN
Specific dynamic load factor	K	100	N/mm ²
Specific static load factor	K	500	N/mm ²
Material constant	K_M	330	

Mass

Mass plain bearing		2.75	kg
--------------------	--	------	----

