

GE 6 E

Dimensions

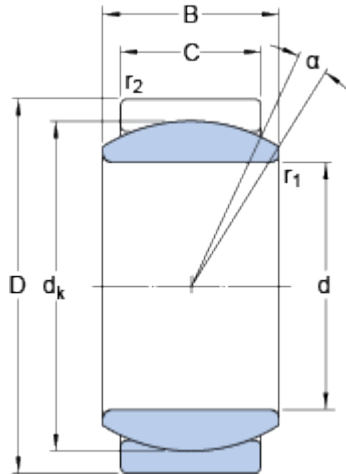

d	6	mm
D	14	mm
B	6	mm
C	4	mm
α	13	°
dk	10	mm
r ₁	min. 0.3	mm
r ₂	min. 0.3	mm

Abutment dimensions

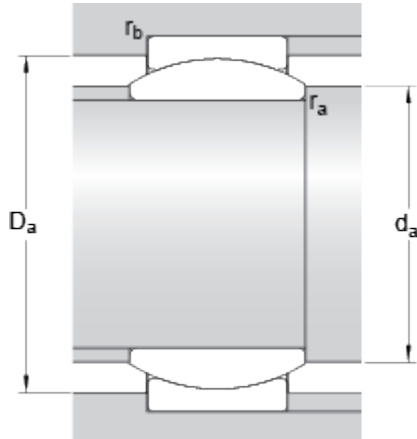

da	min. 7.5	mm
da	max. 8	mm
Da	min. 9.5	mm
Da	max. 12.6	mm
ra	max. 0.3	mm
rb	max. 0.3	mm

Calculation data

Basic dynamic load rating	C	3.4	kN
Basic static load rating	C	17	kN
Specific dynamic load factor	K	100	N/mm ²
Specific static load factor	K	500	N/mm ²
Material constant	K _M	330	

Mass

Mass plain bearing	0.004	kg
--------------------	-------	----