

# GE 45 TXE-2LS

## Dimensions

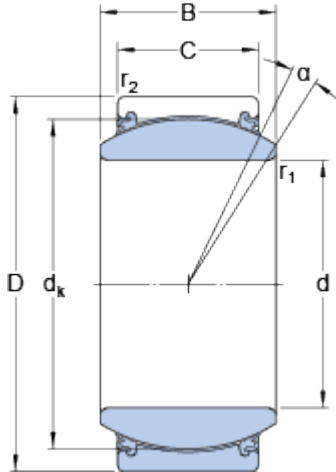

$d$	45	mm
$D$	68	mm
$B$	32	mm
$C$	25	mm
$\alpha$	7	°
$d_k$	60	mm
$r_1$	min. 0.6	mm
$r_2$	min. 1	mm

## Abutment dimensions

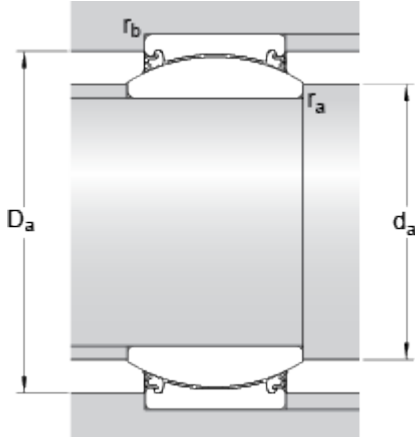

$d_a$	min. 49.5	mm
$d_a$	max. 50.8	mm
$D_a$	min. 61	mm
$D_a$	max. 63.5	mm
$r_a$	max. 0.6	mm
$r_b$	max. 1	mm

## Calculation data

Basic dynamic load rating	C	360	kN
Basic static load rating	C	600	kN
Specific dynamic load factor	K	300	N/mm <sup>2</sup>
Specific static load factor	K	500	N/mm <sup>2</sup>

## Mass

Mass plain bearing		0.04	kg
--------------------	--	------	----