

GE 40 TXE-2LS

Dimensions

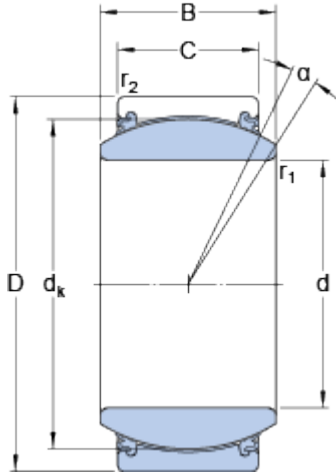

d	40	mm
D	62	mm
B	28	mm
C	22	mm
α	6	°
d_k	53	mm
r_1	min. 0.6	mm
r_2	min. 1	mm

Abutment dimensions

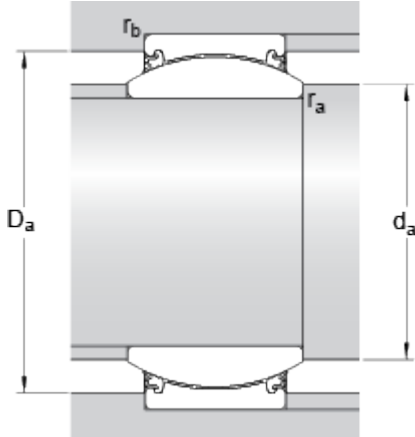

d_a	min.	43.5	mm
d_a	max.	45	mm
D_a	min.	54.5	mm
D_a	max.	57.5	mm
r_a	max.	0.6	mm
r_b	max.	1	mm

Calculation data

Basic dynamic load rating	C	280	kN
Basic static load rating	C	465	kN
Specific dynamic load factor	K	300	N/mm ²
Specific static load factor	K	500	N/mm ²

Mass

Mass plain bearing		0.32	kg
--------------------	--	------	----