

# GE 40 ES-2RS

## Dimensions

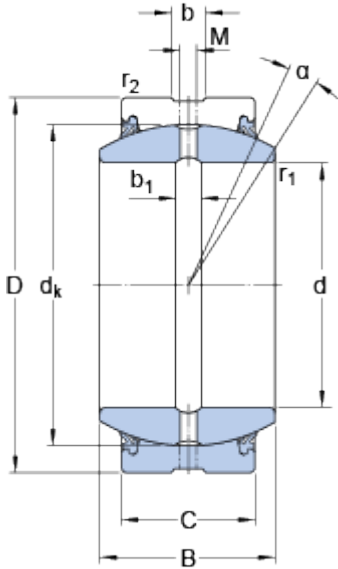

d	40	mm
D	62	mm
B	28	mm
C	22	mm
$\alpha$	6	°
$d_k$	53	mm
b	3.9	mm
$b_1$	3.9	mm
M	2.5	mm
$r_1$	min. 0.6	mm
$r_2$	min. 1	mm

## Abutment dimensions

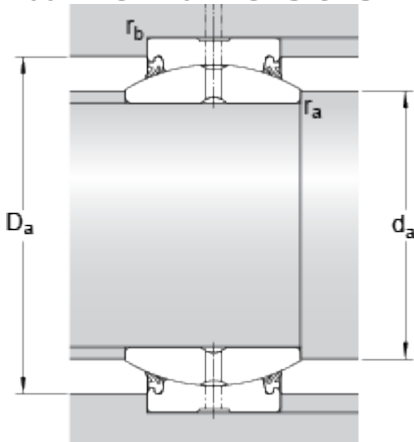

$d_a$	min.	43.6	mm
$d_a$	max.	45	mm
$D_a$	min.	54.5	mm
$D_a$	max.	57.8	mm
$r_a$	max.	0.6	mm
$r_b$	max.	1	mm

## Calculation data

Basic dynamic load rating	C	100	kN
Basic static load rating	C	500	kN
Specific dynamic load factor	K	100	N/mm <sup>2</sup>
Specific static load factor	K	500	N/mm <sup>2</sup>
Material constant	$K_M$	330	

## Mass

Mass plain bearing		0.32	kg
--------------------	--	------	----

