

GE 25 ES-2RS

Dimensions

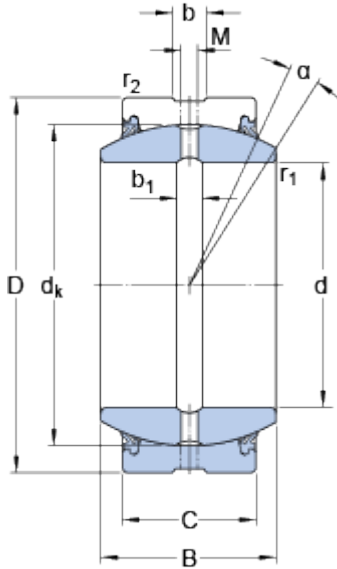

d	25	mm
D	42	mm
B	20	mm
C	16	mm
α	7	°
d_k	35.5	mm
b	3.1	mm
b_1	3.1	mm
M	2	mm
r_1	min. 0.6	mm
r_2	min. 0.6	mm

Abutment dimensions

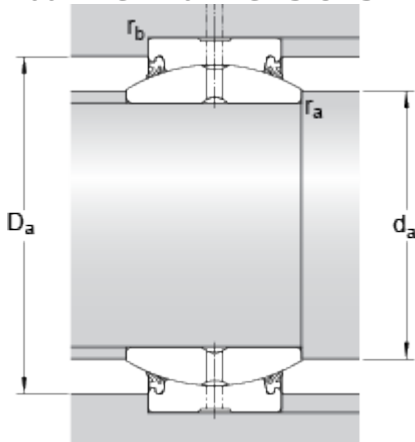

d_a	min.	28.2	mm
d_a	max.	29.3	mm
D_a	min.	36.9	mm
D_a	max.	39.2	mm
r_a	max.	0.6	mm
r_b	max.	0.6	mm

Calculation data

Basic dynamic load rating	C	48	kN
Basic static load rating	C	240	kN
Specific dynamic load factor	K	100	N/mm ²
Specific static load factor	K	500	N/mm ²
Material constant	K_M	330	

Mass

Mass plain bearing		0.12	kg
--------------------	--	------	----

