

GE 20 ES

Dimensions

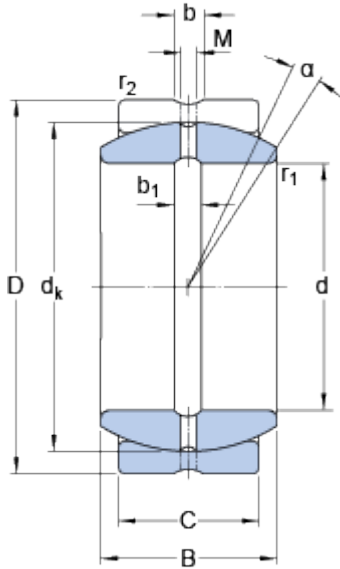

d	20	mm
D	35	mm
B	16	mm
C	12	mm
α	9	°
d_k	29	mm
b	3.1	mm
b_1	3.1	mm
M	2	mm
r_1	min. 0.3	mm
r_2	min. 0.3	mm

Abutment dimensions

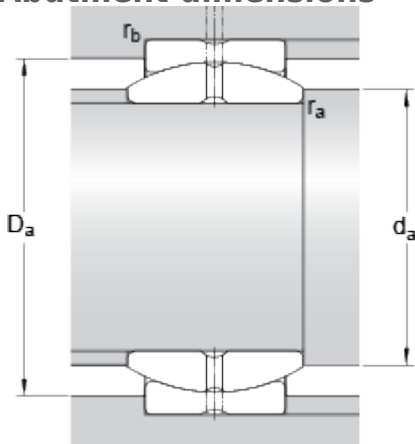

d_a	min.	22.1	mm
d_a	max.	24.2	mm
D_a	min.	27.6	mm
D_a	max.	33.2	mm
r_a	max.	0.3	mm
r_b	max.	0.3	mm

Calculation data

Basic dynamic load rating	C	30	kN
Basic static load rating	C	146	kN
Specific dynamic load factor	K	100	N/mm ²
Specific static load factor	K	500	N/mm ²
Material constant	K_M	330	

Mass

Mass plain bearing	0.065	kg
--------------------	-------	----

