

GEM 60 ES-2RS

Dimensions

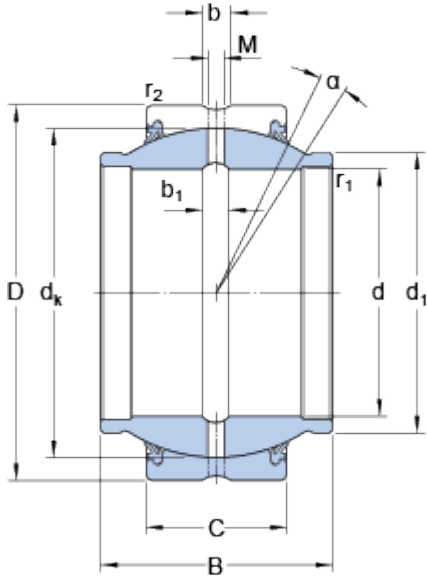

d	60	mm
D	90	mm
B	54	mm
C	36	mm
α	3	°
d_k	80	mm
d_1	≈ 68	mm
b	6.2	mm
b_1	6.2	mm
M	4	mm
r_1	min. 0.6	mm
r_2	min. 1	mm

Abutment dimensions

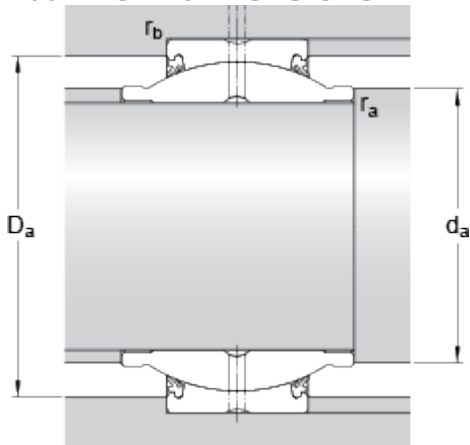

d_a	min.	65.4	mm
d_a	max.	68	mm
D_a	min.	79.7	mm
D_a	max.	84.2	mm
r_a	max.	0.6	mm
r_b	max.	1	mm

Calculation data

Basic dynamic load rating	C	245	kN
Basic static load rating	C	1220	kN
Specific dynamic load factor	K	100	N/mm ²
Specific static load factor	K	500	N/mm ²
Material constant	K_M	330	

Mass

Mass plain bearing		1.15	kg
--------------------	--	------	----

