

GEH 60 ES-2RS

Dimensions

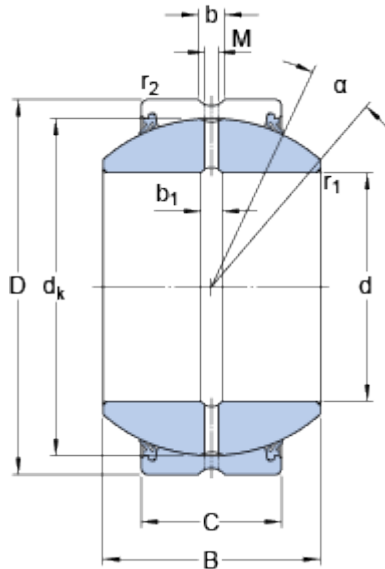

| | | |
|----------|--------|----|
| d | 60 | mm |
| D | 105 | mm |
| B | 63 | mm |
| C | 40 | mm |
| α | 17 | ° |
| d_k | 92 | mm |
| b | 7.7 | mm |
| b_1 | 7.7 | mm |
| M | 4 | mm |
| r_1 | min. 1 | mm |
| r_2 | min. 1 | mm |

Abutment dimensions

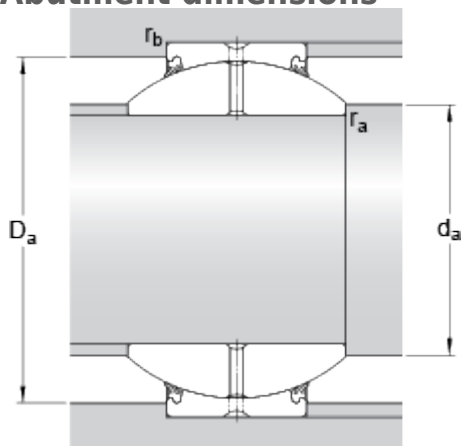

| | | | |
|-------|------|----|----|
| d_a | min. | 67 | mm |
| d_a | max. | 67 | mm |
| D_a | min. | 92 | mm |
| D_a | max. | 99 | mm |
| r_a | max. | 1 | mm |
| r_b | max. | 1 | mm |

Calculation data

| | | | |
|------------------------------|-------|------|-------------------|
| Basic dynamic load rating | C | 315 | kN |
| Basic static load rating | C | 1560 | kN |
| Specific dynamic load factor | K | 100 | N/mm ² |
| Specific static load factor | K | 500 | N/mm ² |
| Material constant | K_M | 330 | |

Mass

| | | | |
|--------------------|--|-----|----|
| Mass plain bearing | | 2.4 | kg |
|--------------------|--|-----|----|

