

# GEH 45 ES-2RS

## Dimensions

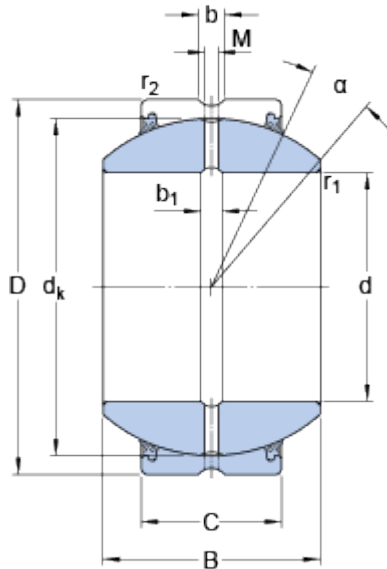

d	45	mm
D	75	mm
B	43	mm
C	28	mm
$\alpha$	14	°
$d_k$	66	mm
b	4.6	mm
$b_1$	4.6	mm
M	3	mm
$r_1$	min. 0.6	mm
$r_2$	min. 1	mm

## Abutment dimensions

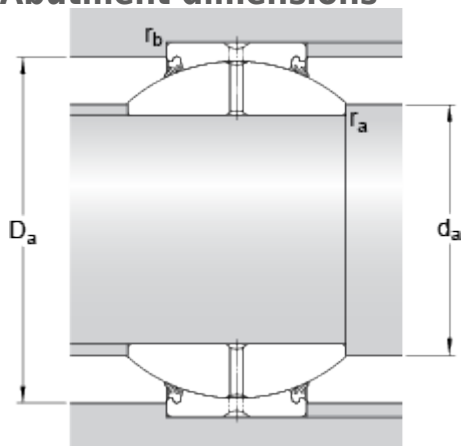

$d_a$	min.	49.8	mm
$d_a$	max.	50.1	mm
$D_a$	min.	66.2	mm
$D_a$	max.	70.5	mm
$r_a$	max.	0.6	mm
$r_b$	max.	1	mm

## Calculation data

Basic dynamic load rating	C	156	kN
Basic static load rating	C	780	kN
Specific dynamic load factor	K	100	N/mm <sup>2</sup>
Specific static load factor	K	500	N/mm <sup>2</sup>
Material constant	$K_M$	330	

## Mass

Mass plain bearing		0.8	kg
--------------------	--	-----	----

