

GEG 32 ES

Dimensions

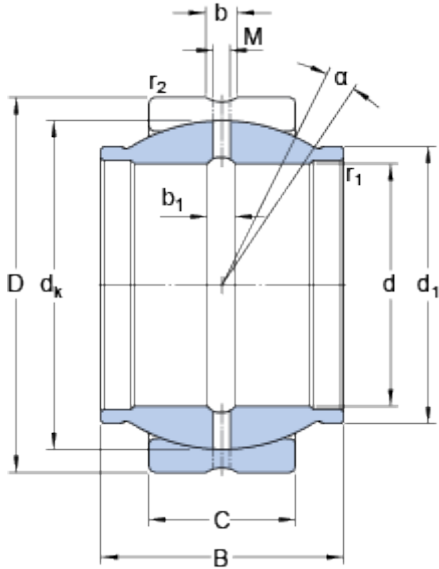

d	32	mm
D	52	mm
B	32	mm
C	18	mm
α	4	°
d_k	43	mm
d_1	≈ 38	mm
b	3.9	mm
b_1	3.9	mm
M	2.5	mm
r_1	min. 0.6	mm
r_2	min. 1	mm

Abutment dimensions

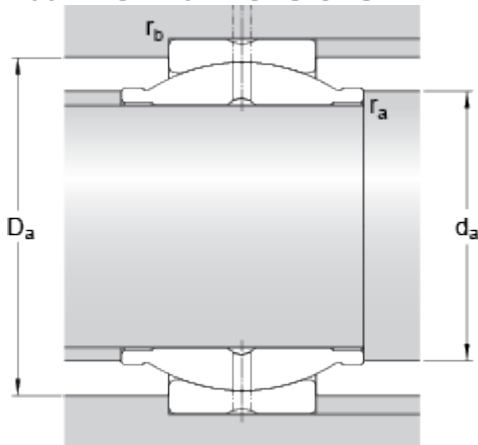

d_a	min.	36.3	mm
d_a	max.	38	mm
D_a	min.	40.9	mm
D_a	max.	48.1	mm
r_a	max.	0.6	mm
r_b	max.	1	mm

Calculation data

Basic dynamic load rating	C	65.5	kN
Basic static load rating	C	325	kN
Specific dynamic load factor	K	100	N/mm ²
Specific static load factor	K	500	N/mm ²
Material constant	K_M	330	

Mass

Mass plain bearing		0.17	kg
--------------------	--	------	----

