

FY 55 TF

Housing material

Cast iron

Dimensions

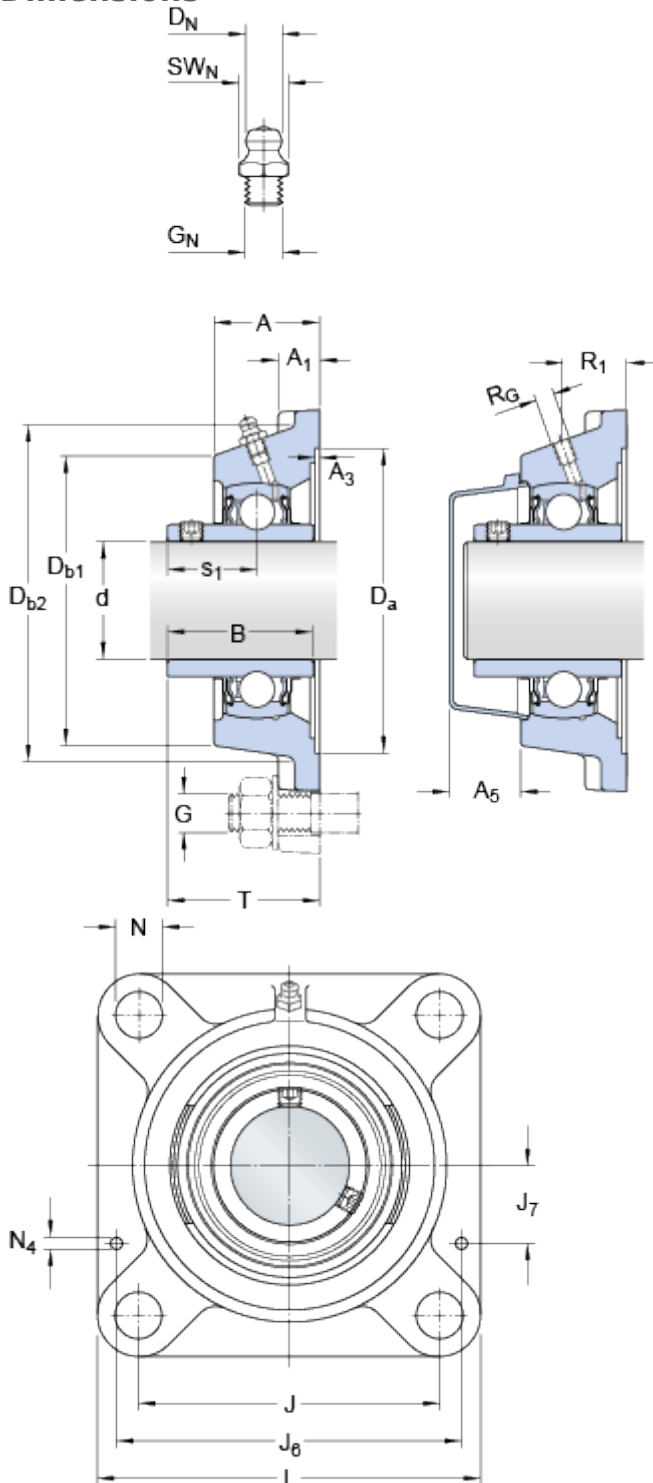

d		55	mm
D _a	H11	150.8	mm
D _{b1}		122	mm
D _{b2}		134	mm
A		47.5	mm
A ₁		16	mm
A ₃	H14	3.2	mm
A ₅		34	mm
B		55.6	mm
J		130	mm
L		162	mm
N		18	mm
s ₁		33.4	mm
T		64.4	mm

Threaded hole

R_G 1/4-28 UNF

R₁ 32 mm

Grease fitting

D_N 6.5 mm

SW_N 7 mm

G_N 1/4-28 SAE-LT

Dowel pins

J₆ 148 mm

J₇ 45 mm

N₄ 4 mm

Calculation data

Basic dynamic load rating

C 43.6 kN

Basic static load rating

C 29 kN

Fatigue load limit

P_u 1.25 kN

Limiting speed

3600 r/min

(with shaft tolerance h6)

Mass

Mass bearing unit	3.2	kg
-------------------	-----	----

Mounting information

Thread grub screw	G ₂	M10x1
Hexagonal key size for grub screw	N	5 mm
Recommended tightening torque for grub screw		16.5 N·m
Recommended diameter for attachment bolts, mm	G	16 mm
Recommended diameter for attachment bolts, inch	G	0.625 in

Included products

Housing	FY 511 M
Bearing	YAR 211-2F

Associated products

End cover	ECY 211
-----------	-------------------------