

FY 30 WF

Housing material

Cast iron

Dimensions

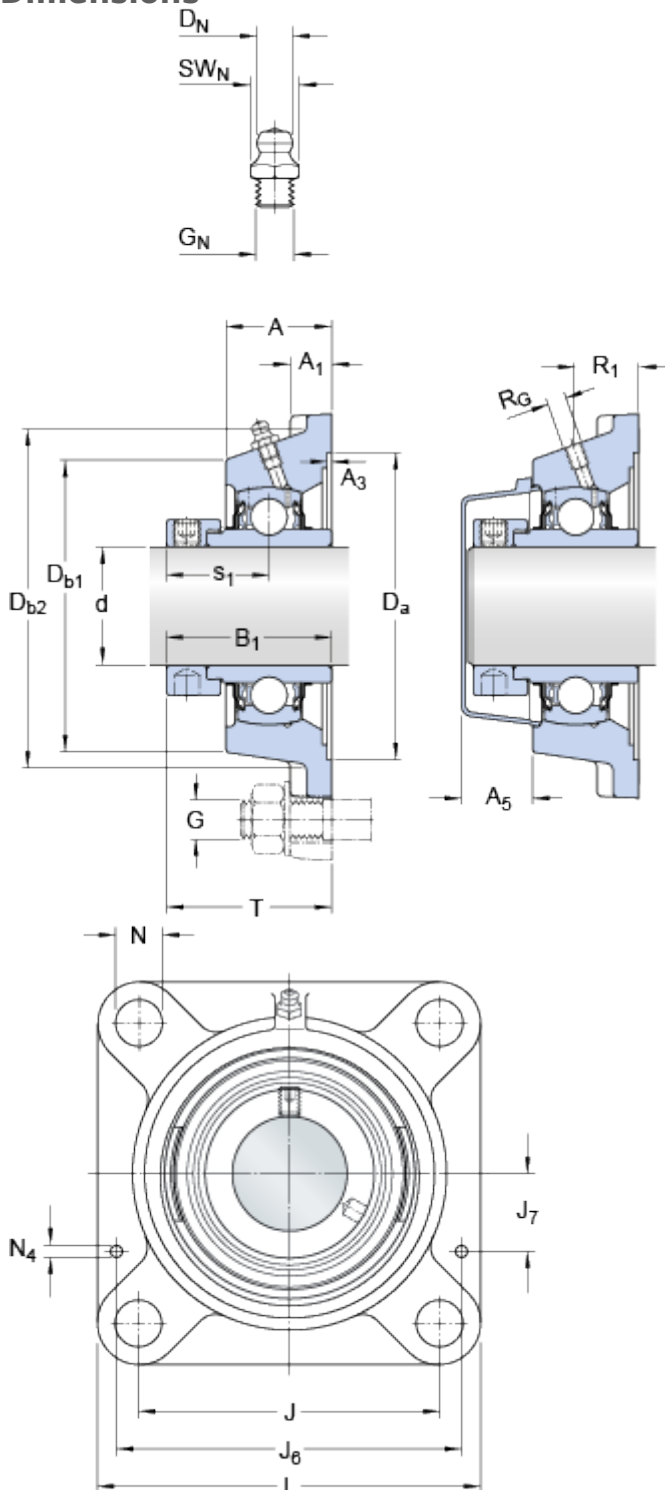

d	30	mm
D _a	H11 93.7	mm
D _{b1}	76	mm
D _{b2}	84	mm
A	32.5	mm
A ₁	13	mm
A ₃	H14 3.2	mm
A ₅	20	mm
B ₁	48.4	mm
J	82.5	mm
L	108	mm
N	11.5	mm
s ₁	30.1	mm
T	50.1	mm

Threaded hole

R_G 1/4-28 UNF

R₁ 21 mm

Grease fitting

D_N 6.5 mm

SW_N 7 mm

G_N 1/4-28 SAE-LT

Dowel pins

J₆ 96 mm

J₇ 24.5 mm

N₄ 4 mm

Calculation data

Basic dynamic load rating	C	19.5	kN
Basic static load rating	C	11.2	kN
Fatigue load limit	P _u	0.475	kN
Limiting speed		6300	r/min

(with shaft tolerance h6)

Mass

Mass bearing unit	1.1	kg
-------------------	-----	----

Mounting information

Thread grub screw	G ₂	M8x1
Hexagonal key size for grub screw	N	4 mm
Recommended tightening torque for grub screw		6.5 N·m
Recommended diameter for attachment bolts, mm	G	10 mm
Recommended diameter for attachment bolts, inch	G	0.375 in

Included products

Housing	FY 506 M
Bearing	YEL 206-2F

Associated products

End cover	ECY 206
-----------	-------------------------