

FY 25 TF

Housing material

Cast iron

Dimensions

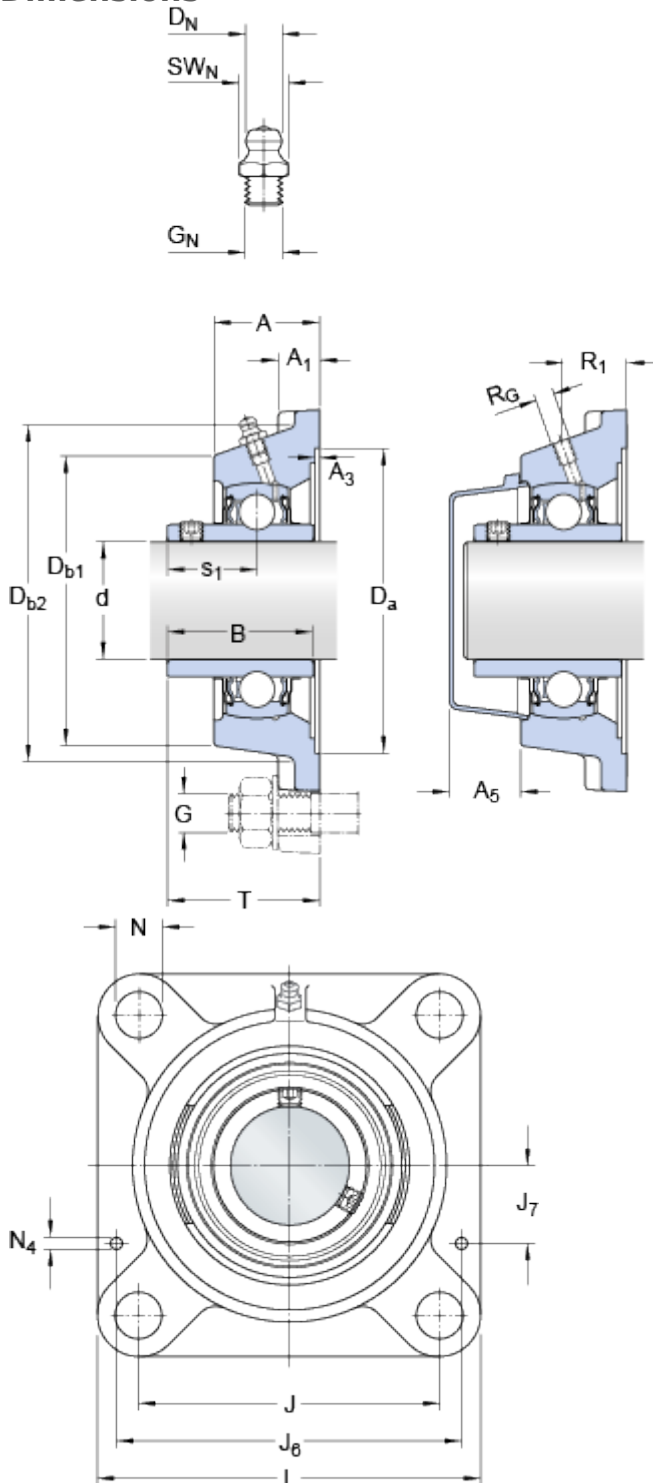

| | | |
|-----|------|------|
| d | 25 | mm |
| Da | H11 | 74.6 |
| Db1 | 65 | mm |
| Db2 | 71 | mm |
| A | 30 | mm |
| A1 | 12 | mm |
| A3 | H14 | 3.2 |
| A5 | 18 | mm |
| B | 34.1 | mm |
| J | 70 | mm |
| L | 95 | mm |
| N | 11.5 | mm |
| s1 | 19.8 | mm |
| T | 38.8 | mm |

Threaded hole

R_G 1/4-28 UNF

R_1 21 mm

Grease fitting

D_N 6.5 mm

SW_N 7 mm

G_N 1/4-28 SAE-LT

Dowel pins

J_6 83 mm

J_7 19 mm

N_4 4 mm

Calculation data

Basic dynamic load rating

C 14 kN

Basic static load rating

C 7.8 kN

Fatigue load limit

P_u 0.335 kN

Limiting speed

7000 r/min

(with shaft tolerance h6)

Mass

| | | |
|-------------------|------|----|
| Mass bearing unit | 0.69 | kg |
|-------------------|------|----|

Mounting information

| | | |
|---|----------------|----------|
| Thread grub screw | G ₂ | M6x0.75 |
| Hexagonal key size for grub screw | N | 3 mm |
| Recommended tightening torque for grub screw | | 4 N·m |
| Recommended diameter for attachment bolts, mm | G | 10 mm |
| Recommended diameter for attachment bolts, inch | G | 0.375 in |

Included products

| | |
|---------|----------------------------|
| Housing | FY 505 M |
| Bearing | YAR 205-2F |

Associated products

| | |
|-----------|-------------------------|
| End cover | ECY 205 |
|-----------|-------------------------|