

FYWK 25 YTH

Housing material

Composite for food and beverage

Dimensions

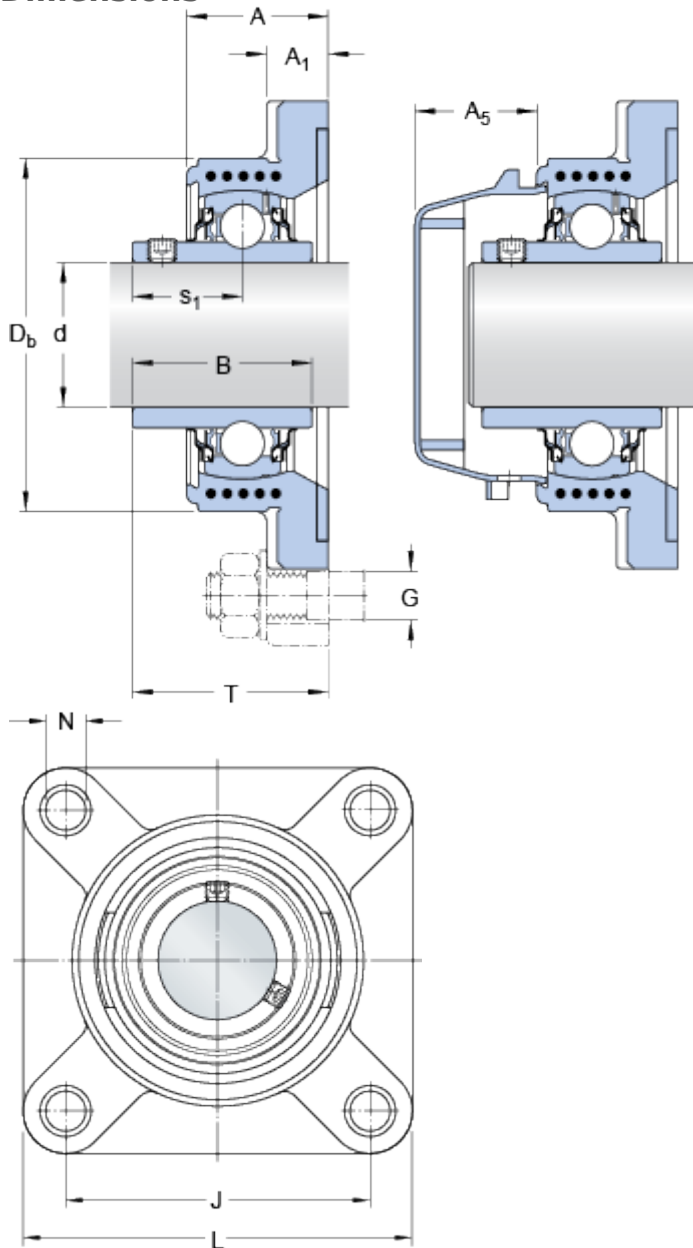

d	25	mm
D_b	65	mm
A	31	mm
A_1	15	mm
A_5	25.5	mm
B	34.1	mm
J	70	mm
L	95	mm
N	12.3	mm
s_1	19.8	mm
T	38.8	mm

Calculation data

Basic dynamic load rating	C	11.9	kN
Basic static load rating	C	7.8	kN
Fatigue load limit	P_u	0.335	kN
Limiting speed		4300	r/min

(with shaft tolerance h6)

Mass

Mass bearing unit		0.36	kg
-------------------	--	------	----

Mounting information

Thread grub screw	G_2	M6x0.75	
Hexagonal key size for grub screw	N	3	mm

Recommended tightening torque for grub screw		4	N·m
Recommended diameter for attachment bolts, mm	G	10	mm
Recommended diameter for attachment bolts, inch	G	0.375	in

Included products

Housing	FYWK 505 Y
Bearing	YAR 205-2RF/HV

Assosiated products

End cover	ECW 205
-----------	-------------------------