

FYTB 509 M

Dimensions

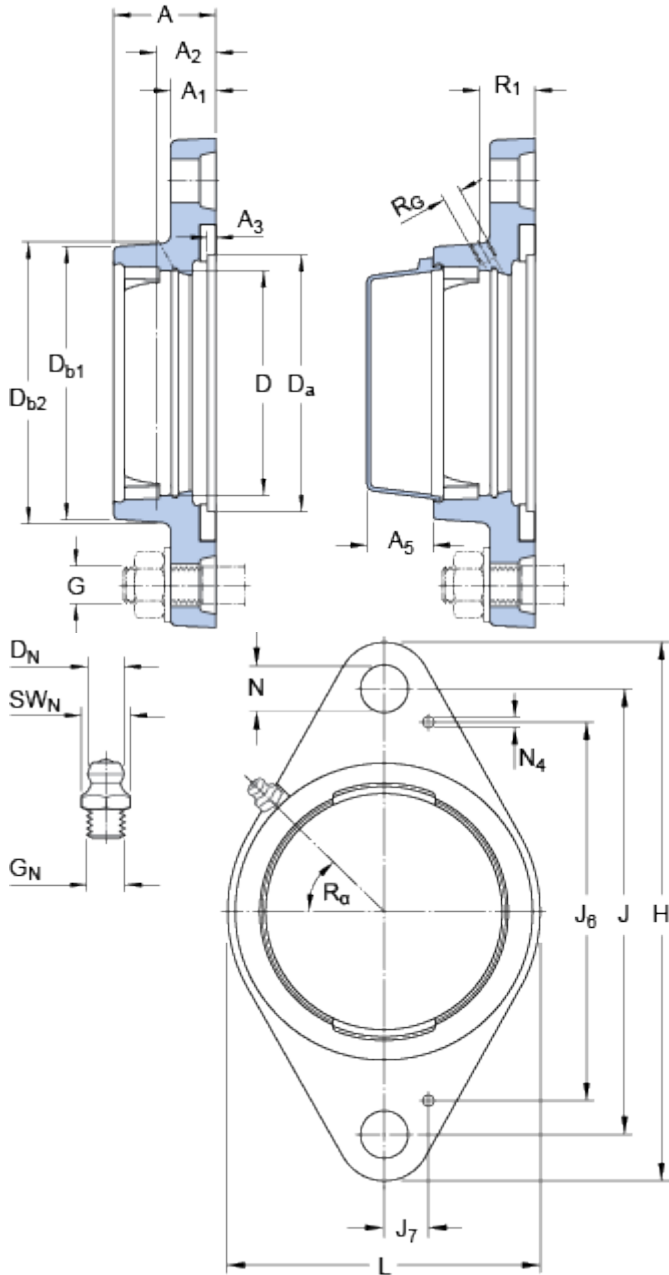

D		85	mm
D _a	H11	98.4	mm
D _{b1}		102	mm
D _{b2}		111	mm
A		39	mm
A ₁		14	mm
A ₂		24	mm
A ₃	H14	3.2	mm
A ₅		23	mm
J		148.5	mm
H		178.5	mm
L		111	mm
N		16	mm

Threaded hole

R _G		1/4-28 UNF	
R ₁		24.5	mm
R _α		45	°

Grease fitting

D _N		6.5	mm
SW _N		7	mm
G _N		1/4-28 SAE-LT	

Dowel pins

J ₆		120.5	mm
J ₇		18	mm
N ₄		2	mm

Mass

Mass housing		1.1	kg
--------------	--	-----	----

Mounting information

Recommended diameter for attachment bolts, mm	G	14	mm
Recommended diameter for attachment bolts, inch	G	0.5625	in

Appropriate products

End cover		ECY 209	
-----------	--	---------	--

