

# FYTB 507 M

## Dimensions

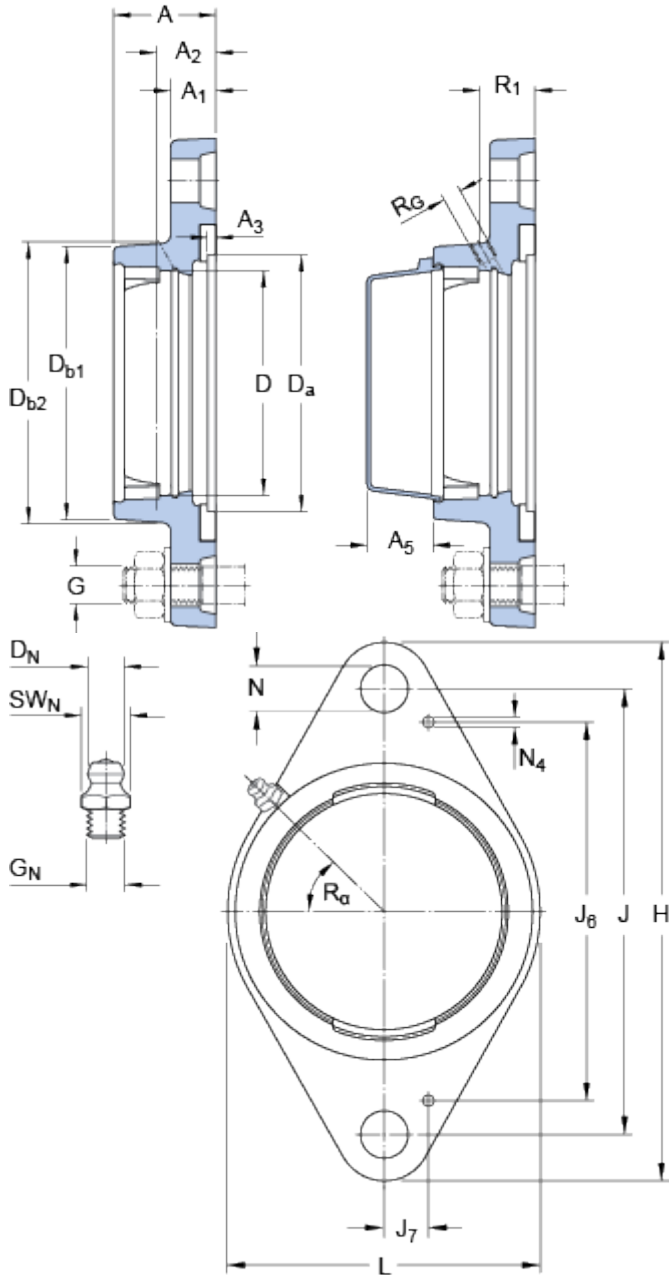

D		72	mm
D <sub>a</sub>	H11	88.9	mm
D <sub>b1</sub>		88	mm
D <sub>b2</sub>		96	mm
A		34.5	mm
A <sub>1</sub>		13	mm
A <sub>2</sub>		21	mm
A <sub>3</sub>	H14	3.2	mm
A <sub>5</sub>		22	mm
J		130	mm
H		156	mm
L		96	mm
N		14	mm

### Threaded hole

R <sub>G</sub>		1/4-28 UNF
R <sub>1</sub>		22 mm
R <sub>α</sub>		45 °

### Grease fitting

D <sub>N</sub>		6.5 mm
SW <sub>N</sub>		7 mm
G <sub>N</sub>		1/4-28 SAE-LT

### Dowel pins

J <sub>6</sub>		106 mm
J <sub>7</sub>		15 mm
N <sub>4</sub>		2 mm

## Mass

Mass housing	0.75	kg
--------------	------	----

## Mounting information

Recommended diameter for attachment bolts, mm	G	12	mm
Recommended diameter for attachment bolts, inch	G	0.5	in

## Appropriate products

End cover	ECY 207
-----------	---------

