

# FYTB 505 M

## Dimensions

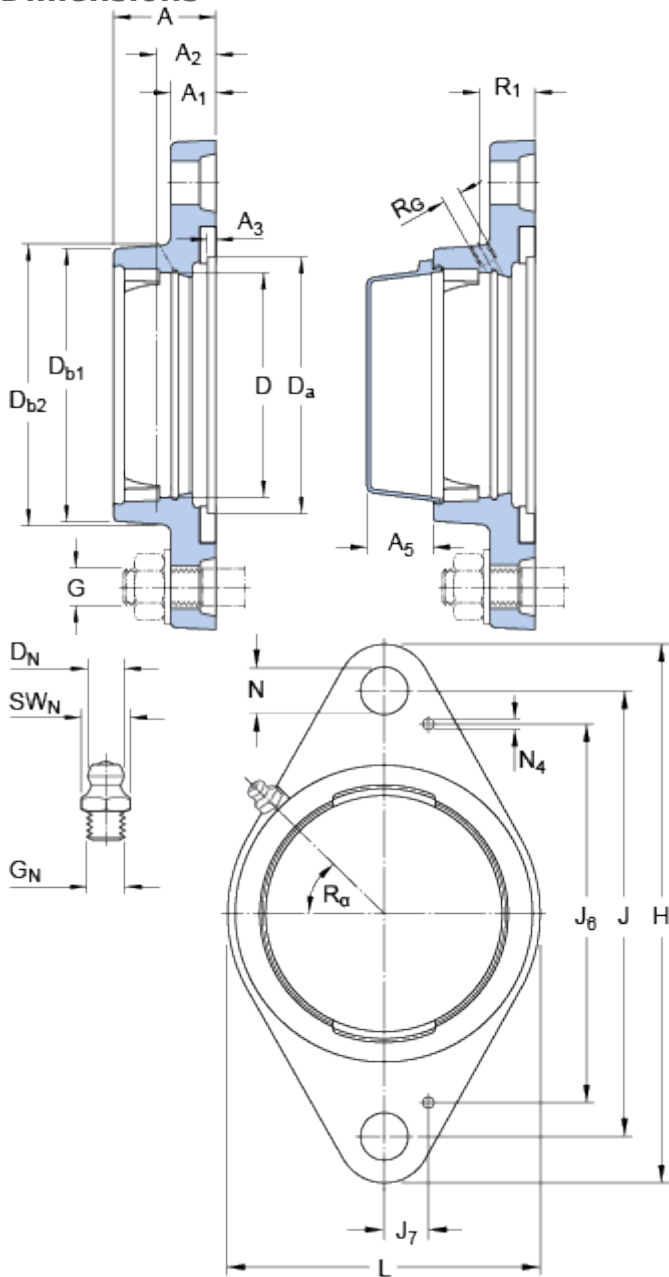

D		52	mm
D <sub>a</sub>	H11	63.5	mm
D <sub>b1</sub>		65	mm
D <sub>b2</sub>		70	mm
A		30	mm
A <sub>1</sub>		12	mm
A <sub>2</sub>		19	mm
A <sub>3</sub>	H14	3.2	mm
A <sub>5</sub>		18	mm
J		99	mm
H		124	mm
L		70	mm
N		11.5	mm

### Threaded hole

R <sub>G</sub>		1/4-28 UNF	
R <sub>1</sub>		20.5	mm
R <sub>α</sub>		45	°

### Grease fitting

D <sub>N</sub>		6.5	mm
SW <sub>N</sub>		7	mm
G <sub>N</sub>		1/4-28 SAE-LT	

### Dowel pins

J <sub>6</sub>		81	mm
J <sub>7</sub>		12	mm
N <sub>4</sub>		2	mm

## Mass

Mass housing	0.39	kg
--------------	------	----

## Mounting information

Recommended diameter for attachment bolts, mm	G	10	mm
Recommended diameter for attachment bolts, inch	G	0.375	in

## Appropriate products

End cover	ECY 205
-----------	---------

