

FYTB 35 TF

Housing material

Cast iron

Dimensions

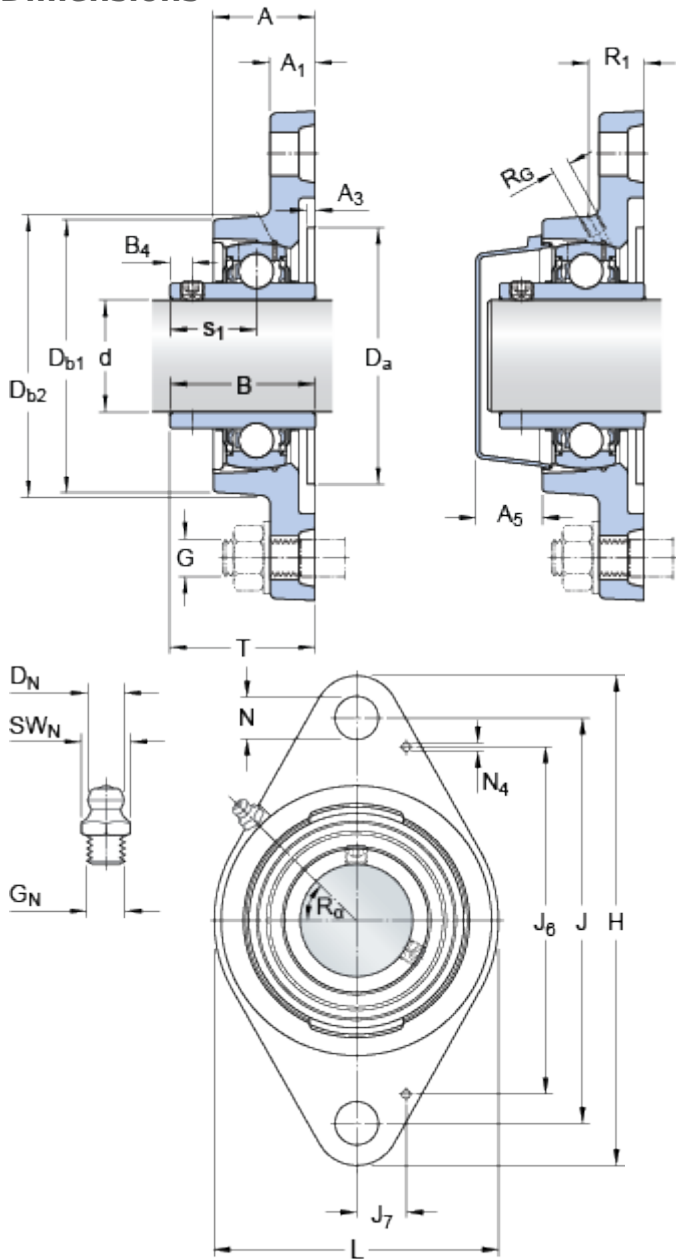

d		35	mm
D _a	H11	88.9	mm
D _{b1}		88	mm
D _{b2}		96	mm
A		34.5	mm
A ₁		13	mm
A ₃	H14	3.2	mm
A ₅		22	mm
B		42.9	mm
B ₄		6	mm
J		130	mm
H		156	mm
L		96	mm
N		14	mm
s ₁		25.4	mm
T		46.4	mm

Threaded hole

R _G		1/4-28 UNF	
R ₁		22	mm
R _α		45	°

Grease fitting

D _N		6.5	mm
SW _N		7	mm
G _N		1/4-28 SAE-LT	

Dowel pins

J ₆		106	mm
J ₇		15	mm
N ₄		2	mm

Calculation data

Basic dynamic load rating	C	25.5	kN
Basic static load rating	C	15.3	kN
Fatigue load limit	P _u	0.655	kN

Limiting speed	5300	r/min
(with shaft tolerance h6)		

Mass

Mass bearing unit	1.15	kg
-------------------	------	----

Mounting information

Thread grub screw	G ₂	M6x0.75
Hexagonal key size for grub screw	N	3 mm
Recommended tightening torque for grub screw		4 N·m
Recommended diameter for attachment bolts, mm	G	12 mm
Recommended diameter for attachment bolts, inch	G	0.5 in

Included products

Housing	FYTB 507 M
Bearing	YAR 207-2F

Associated products

End cover	ECY 207
-----------	-------------------------